



Known for Reliability Since 1921

The Biro 6642 Meat Grinder is a versatile manual feed grinder that can be used as either a compact or a large counter-top grinder. Its 2 HP motor has plenty of power, and the size 42 head and wide angle bowl ensure good productivity. The 6642's compact size means it can fit into tight places, which makes it ideal for meat shops, small grocery store meat rooms, and commercial or institutional kitchens. The exclusive Biro oil bath type transmission with double reduction steel gears ensures quiet, trouble-free operation for many years. The bowl assembly and feed tray are easily removed without tools, so cleanup is a snap. Quiet and easy operation, durability, and low maintenance all help make the Biro 6642 hold its value for many years.



Model 6642
Shown as Standard



Model 6642
Shown with Optional
22" (559 mm) Aluminum Extension Legs

6642

MODEL 6642 SPECIFICATIONS

Model: 6642 Grinder (Chopper, Mincer).

Motors:

HP	TYPE	KW	VOLTS	AMPS	CYCLE	PH	STATUS
2	ODP	1.5	208-230/460	6.4-5.8/2.9	60	3	STD
2	ODP	1.5	115/208-230	28/15-14	60	1	STD
2	ODP	1.5	104/208	31/15.5	60	1	NC
2	ODP	1.5	208	6.4	60	3	NC
2	ODP	1.5	220/380-415	6/3.5-3.1	50	3	NC

ODP = Open Drip Proof STD = Standard NC = No Charge
EC = Extra Charge



Construction: Stainless Steel Feed Pan and Polished Stainless Steel Case, Cast Iron Hot Tin Dipped Bowl, Ring and Auger, Size 32.

Switch and Interlock: Magnetic Contactor with Waterproof Push Buttons Mounted on Right side of Machine (Factory Installed) When Facing Bowl and Feed Pan Interlock. Push Buttons Can Be Optionally Mounted on Left Side of the Stainless Steel Case.

Feed Pan Capacity: Approximately 75 lbs. (34 kg).

Grinding Capacity: Up to 41 lbs. (18.6 kg) per Minute, 3/8" Plate First Grind.

Drive System: Direct Drive Oil Bath Transmission and Double Reduction Steel Gears, Tapered Roller Bearings.

Safety: Magnetic Interlock so Machine will NOT Operate when Feed Pan with Welded Bowl Guard is Removed.

Standard Features: 4" Aluminum Legs • Splash Guard • Stomper • Stainless Steel Welded Bowl Guard on Feed Pan • Operating and Safety Manual.

Options (EC): Size 32/42 Knife and Plate (Specify Plate Hole Size Required) • Power Cord Less Plug • Longer 22" (559 mm) Aluminum Legs (Shown on front) • Solid Stomper.

Certification: U.L., N.S.F., U.S.D.A., C.S.A. on 115 Volt 1 phase, 208/230 3 phase.

Weight: 1 Phase Uncrated: 243 lbs. (110 kg.) Approximate.
1 Phase Crated: 280 lbs. (127 kg.) Approximate.
3 Phase Uncrated: 222 lbs. (101 kg.) Approximate.
3 Phase Crated: 260 lbs. (118 kg.) Approximate.

Dims. Crated: L = 25"(635 mm), W = 45"(1143 mm),
H = 31"(787 mm).

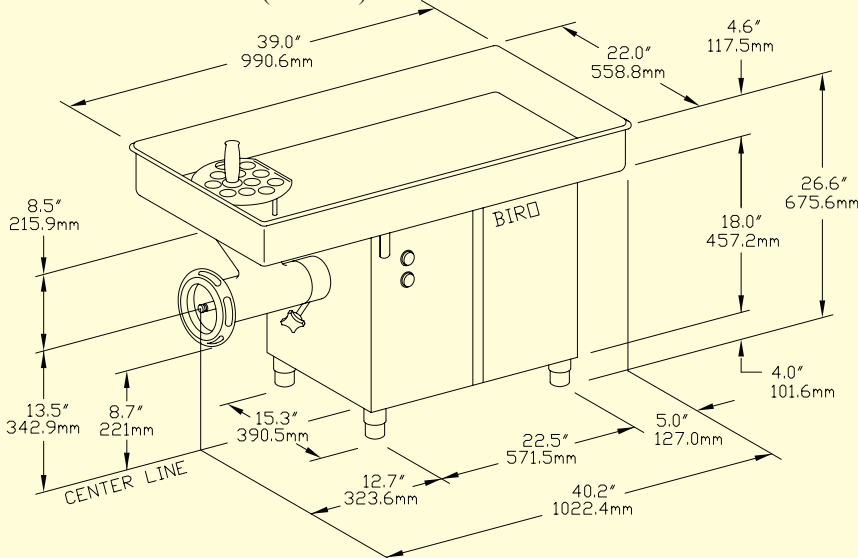

All specifications contained herein are subject to change without notification.

1/8" (3.2 mm)



3/8" (9.5 mm)

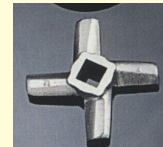
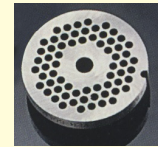

Extra cost, size 32 knife and plate.
Plate hole sizes available listed below.

MC32-17	Knife, 4 Blade
MC32-18-125	Plate, 1/8" Holes (3.2 mm)
MC32-18-156	Plate, 5/32" Holes (4.0 mm)
MC32-18-187	Plate, 3/16" Holes (4.3 mm)
MC32-18-375	Plate, 3/8" Holes (9.5 mm)

BIRO MANUFACTURING COMPANY
1114 WEST MAIN STREET
MARBLEHEAD, OH 43440-2099 U.S.A.

Phone: (419) 798-4451
Fax: (419) 798-9106

<http://www.birosaw.com>
sales@birosaw.com

ITEM NO.: LIT-6642-179

FORM NO.: Md 6642-179-4-15-17-B

Service is available from locations worldwide